

CARDIO

UK

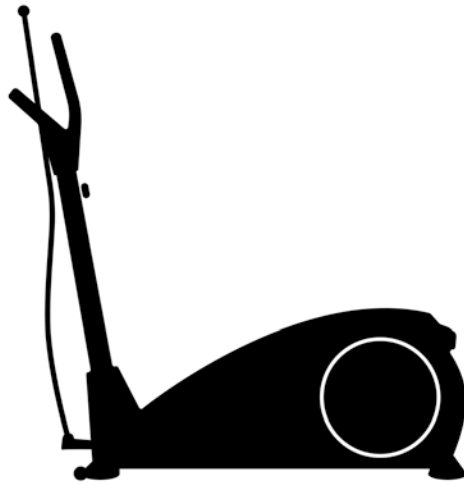

---

# ATHLETE C'55

---

TITAN LIFE®

---



# TABLE OF CONTENTS

READ THROUGH THE INSTRUCTION BEFORE USE	4
DEAR CUSTOMER	5
CUSTOMER SERVICE	6
DISPOSAL	7
WARRANTY PROVISIONS	8
SAFETY MEASURES	10
MAINTENANCE	13
HEART RATE-BASED TRAINING	14
WARMING UP	16
GENERAL EXERCISE PROGRAMME	19
HELP IN ATTAINING YOUR EXERCISE GOALS	20
INSTRUCTIONS	21



# READ THROUGH THE INSTRUCTION BEFORE USE

IF YOU WANT YOUR PRODUCT TO LAST LONGER.

READ THROUGH THE MAINTENANCE SECTION BEFORE USE.

# DEAR CUSTOMER

We are so happy you have chosen a product from TITAN LIFE. This quality product has been manufactured for home use and has been tested according to European Standard EN 957. Before you assemble and begin using the product, we ask you to carefully read through the instructions for use and to keep them in a safe place in case you need them later.

# CUSTOMER SERVICE

In order for us to offer you the best service whenever you have any questions or in case anything should go wrong, we would ask you to note down the product serial number, which can be found on a label on the bottom of the treadmill frame. Then, fill in the following paragraphs for future reference. This information will be needed, if at any time, you have to contact us regarding your product. We also recommend you keep the following information stored with your receipt of purchase. You are obligated to show your receipt in the event of any claim.

Brand:

---

e.g., TITAN LIFE

Product type:

---

e.g. Bike

Product name:

---

e.g. ATHLETE B'11

Serial number:

---

e.g. re-12011/5212/45101-01

Date of purchase:

---

e.g. 20/10/2020

Where purchased:

---

e.g. Expert Sport Norway

## ORDERING SPARE PARTS

If you need to buy any spare parts, you will find the product numbers for these in the product description documentation or the instructions for use. When ordering, contact our service department as follows:

DK: [www.livingsport.dk](http://www.livingsport.dk)

SE: [www.livingsport.se](http://www.livingsport.se)

FI: [www.livingsport.fi](http://www.livingsport.fi)

NO: [www.livingsport.eu](http://www.livingsport.eu)

DE: [www.livingsport.info](http://www.livingsport.info)

EN: [www.livingsport.info](http://www.livingsport.info)

Have the serial number, product name, your receipt and user manual ready when you get in touch with us.

## DISPOSAL

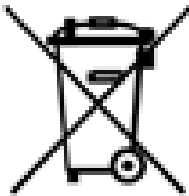

This symbol on a product means that it must not be disposed of as household waste. It is your responsibility to take the product to an appropriate collection point for recycling electrical and electronic equipment. This procedure help in conserving natural resources and prevents potential negative consequences for human health and the environment.



# WARRANTY PROVISIONS

TITAN LIFE quality products are designed and tested for home use. This means that the warranty becomes completely null and void if the product is used for commercial, public or other non-private use. This product is manufactured according to European Standard EN 957. As an importer of your new TITAN LIFE product, LivingSport A/S offers a 2 year warranty under the Sale of Goods Act. This warranty covers manufacturing and material defects found during normal use of the product. The warranty does not cover defects, damage or wear caused directly or indirectly by improper use, poor maintenance, violent use or unauthorised modification. LivingSport A/S cannot be held liable for damage to other household goods incurred in connection with the use of the product. Claims in respect of defects and shortcomings that should be detected through normal examination of the product should be communicated to LivingSport A/S within a reasonable time.

In the event of defects or shortcomings in the product, it can be returned for repair. This SHALL be agreed upon with LivingSport A/S prior to the return of the product. After evaluation of the extent of the defect or shortcoming, an attempt will be made to remedy the problem by repairing the product. If this cannot be done within a reasonable time and without major inconvenience to the consumer, the product will be exchanged or a credit issued. The claim period begins on the day of delivery. So, please save your purchase receipt and delivery advice.

If you wish to make a product claim, please go to:

DK: [www.livingsport.dk](http://www.livingsport.dk)

SE: [www.livingsport.se](http://www.livingsport.se)

FI: [www.livingsport.fi](http://www.livingsport.fi)

NO: [www.livingsport.eu](http://www.livingsport.eu)

DE: [www.livingsport.info](http://www.livingsport.info)

EN: [www.livingsport.info](http://www.livingsport.info)

# SAFETY MEASURES

Before beginning this or any other exercise programme you should consult your doctor. This is particularly important for people who have not exercised regularly before or individuals with current or previous health problems. Read this manual carefully before you begin your workout. The manufacturer and retailer assume no liability for injury or damage caused by or through the use of this product. Neither the manufacturer nor the seller is responsible for personal injury or damage to household goods due to or connected to use of this product.

Read through all precautions and instructions thoroughly before you use the exercise equipment. We recommend that you save this manual for future reference.

- It is the responsibility of the owner to ensure that all users of the product are adequately informed of all precautions. Use the product only as described in this manual.
- Use the product indoors on a flat surface with sufficient free space around the product. Do not place the product outdoors, in the garage, carport, shed or near water.
- Protect the product from moisture and dust.
- ALWAYS keep children under 12 and pets away from the product.
- If necessary, place a mat under the stabilisers to protect wooden floors and carpets.
- Tighten all screws and bolts regularly.
- Immediately replace any worn parts.

- Damaged parts or components may pose a risk to your safety or reduce the lifetime of the product. Therefore, replace damaged or worn parts immediately and do not use the product before you do this.
- Repairs may only be carried out in consultation with LivingSport A/S.
- Ensure that NO LIQUID enters the machine or electronic parts as this may cause damage to the product.
- The product should be stored at normal room temperature – not below 15°C.
- Use appropriate clothing when exercising. Do not wear loose clothing that could get tangled in the product's moving parts.
- Always wear athletic shoes or trainers when exercising.
- Keep your back straight while exercising on the product. Do not bend your back. If you feel pain or dizziness while exercising, you should immediately stop.
- If your product is used in conjunction with a hand pulse monitor, be aware that such a device is not a medical appliance and that you can expect a greater margin of error when measuring your heart rate as compared with the measurements of your pulse rate direct from your heartbeat. Several factors, including the way the user moves, can influence the precision of a hand pulse meter.
- The hand pulse monitor should be regarded as a training tool to determine your general heart rate.

- The product is classified as an "H" product (for home use) and is therefore only intended for private exercise. It should not be used for commercial or institutional conditions.
- The product is NOT designed for medical and rehabilitative purposes.
- The product is manufactured according to European Standard EN 957 and is not intended for therapeutic or medical training.
- For maximum user weight read through the INSTRUCTIONS section.
- If your product has heart rate then please note this: WARNING! Heart rate monitoring systems may be inaccurate. Over exercising may result in serious injury or death. If you feel faint stop exercising immediately.

# MAINTENANCE

The product must be tensioned before each occasion of use and it should be checked for defects, vibrations, noise and rattling and missing parts. If you are unsure whether the product has a defect, cease using it and contact LivingSport A/S' service department. In particular, take note of the screws securing the moving parts, whether visible or hidden. If the fault has occurred due to improper use, lack of tensioning or maintenance, the warranty is void at any time. Furthermore, LivingSport A/S takes no responsibility for faults which may occur on 2<sup>nd</sup> and 3<sup>rd</sup> parties.

# HEART RATE-BASED TRAINING

On normal days our body uses oxygen to convert nutrients from the food we eat into energy for use by our muscles and for other bodily functions. The amount of energy we use is measured in calories. Generally speaking, if we burn more calories than we take in, the body will use existing fat as an energy reservoir, and this will lead to a transformation of fat to muscle. This gives us a better posture and better general health.

When we exercise, our heart rate increases to facilitate the supply of oxygen to the muscles that are being used. Regular cardiovascular activity such as cycling, running, rowing or training on a cross trainer will result in a stronger heart and stronger lungs that can more effectively distribute oxygen to the muscles, which in turn can more effectively burn calories.

However, to ensure you improve your health in a safe and reliable way it is necessary that you very accurately estimate the pulse rate you are going to train at.

You do this by setting your maximum heart rate (maximum heart rate (MHR)). This is the maximum number of times your heart is allowed to beat per minute.

General setting of maximum heart rate:

Men:                      Calculated heart rate =  $220 -$

age Women:            Calculated heart rate =  $226 -$

age

The table on this page is a guide to help you determine the level at which you should exercise based on your maximum heart rate (MHR).

### HEART RATE DIAGRAM

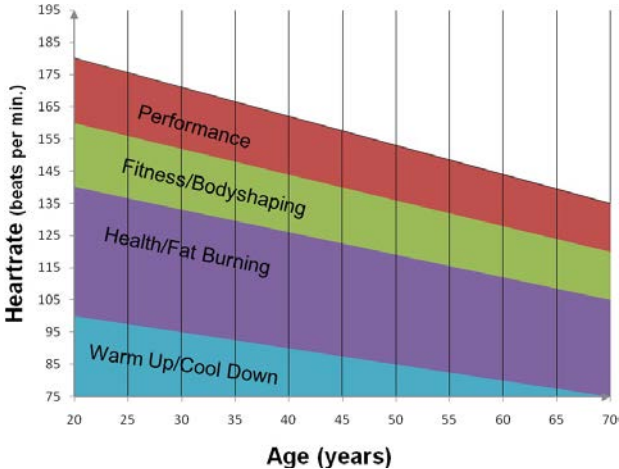



# WARMING UP

## FLEXIBILITY

Flexibility is the area of movement around a joint where two or more bones come together. By maintaining your joints and improving your flexibility, you will be less susceptible to injury or arthritic infirmity. You should try to gently improve your flexibility using a couple of stretching exercises. Stretching exercises should always be a part of your warm up and cool down routines. You can then continue to increase your flexibility during your normal workout.

## WARMING UP AND COOLING DOWN

A successful exercise programme consists of a good warm up, aerobic exercising and cool down. Follow this programme two or three times a week with a day between workouts. After several months you can increase your workouts to four or five times a week. Warming up is a very important component of your exercise programme and it should be done before every workout. It prepares your body for a very strenuous workout by warming up and stretching your muscles. It also improves your circulation and increases your pulse rate, and delivers more oxygen to your muscles. After the workout, you should repeat these exercises to reduce exercise pain. Try the following warming up and cooling down exercises.

## TOUCHING YOUR TOES

Slowly bend your back from the hips, keeping your back and arms relaxed while stretching downwards toward your toes. Stretch down as far as you can and hold that position for 15 seconds. Bend the knees slightly.

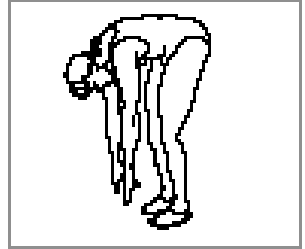

## SHOULDER LIFTS

Raise your right shoulder up towards your ear and hold for 2 seconds. Then repeat for your left shoulder while lowering the right.



## HAMSTRING STRETCHED

Sit with your right leg outstretched. Rest the sole of the left foot against the inside of your right thigh. Stretch your right arm out along your right leg as far as you can. Hold for 15 seconds. Relax and then repeat with the left leg and left arm.

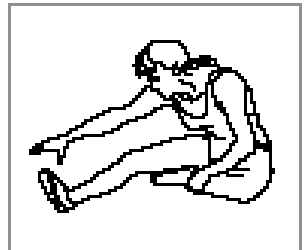

## SIDE STRETCHES

Raise your arms above your head. Stretch your right arm up towards the ceiling as far as you can. Stretch your upper body towards the right side. Then repeat the exercise for the left side.



## CALF/ACHILLES STRETCHES

Lean against a wall with your left leg in front of the right and your arms forward. Stretch out your right leg and keep your left foot on the floor. Then bend your left leg and lean forwards by moving your right hip in the direction of the wall. Hold for 15 seconds. Keep your leg stretched and repeat the exercise for the other leg.

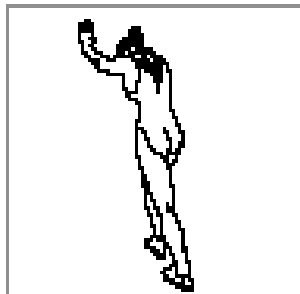

## HEAD ROLLS

Slowly tilt your head to the right, stretching out the left side of your neck. Hold for 20 seconds. Then tilt it back again to the left and continue on until the right side of your neck is stretched out. And hold for 20 seconds. Then, slowly tilt your head forwards and stick out your neck. Don't rotate your head all the way round.

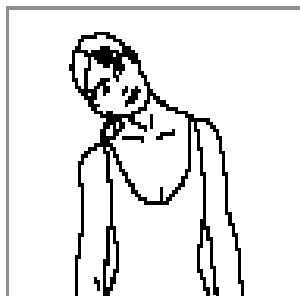

Repeat the exercises several times.

# GENERAL EXERCISE PROGRAMME

DESIRED RESULT	EXERCISE LEVEL
<p>More active lifestyle</p> <ul style="list-style-type: none"> <li>● Improve functional capacity</li> <li>● Reduce the risk of disease</li> <li>● physical well-being</li> </ul>	<p>Level 1</p> <p>Work with a heart rate of 40-60% of your maximum</p>
<p>Healthier heart – burn off fat</p> <ul style="list-style-type: none"> <li>● Improved cardiovascular health</li> <li>● Weight loss</li> <li>● More energy</li> <li>● Reduced blood pressure</li> <li>● Reduced cholesterol level</li> <li>● Increased immunity levels</li> <li>● Reduced stress</li> </ul>	<p>Level 2</p> <p>Work with a heart rate of 61-70% of your maximum</p>
<p>Fitness – stamina</p> <ul style="list-style-type: none"> <li>● Improved cardiovascular health</li> <li>● Improved aerobic capacity and</li> </ul>	<p>Level 3</p> <p>Work with a heart rate of 71-85% of your maximum</p>
<p>Competition training</p> <ul style="list-style-type: none"> <li>● Shift oxygen limit</li> <li>● Improve competition results</li> </ul>	<p>Level 4</p> <p>Work with a heart rate of 86-100% of your maximum</p>

# HELP IN ATTAINING YOUR EXERCISE GOALS

As previously described, there are a range of benefits from exercising, including better sleeping habits and increased metabolism so that you burn fat even when you are not exercising, improved posture that reduces the risk of back pain and enhanced self-esteem as a result of all the benefits to your health. Don't make weight loss the only objective for your workouts – your reflection in the mirror is a much better indicator, since you will be converting fat into muscles.

Don't set unrealistic objectives when you begin working out. That will quickly give rise to sore muscles and then you will lack motivation when you fail to achieve your goals. Instead, it's better for you to sit on the bicycle seat for 20 minutes, 3 times a week and let your body recover between workouts. Remember what you're putting into effect is a change of lifestyle, so let it take the time it takes.

Try not to do too much at once to get in shape. Success over the long term tends to be easier to achieve when you start slowly. Take one step at a time and make sure that your new habits feel normal to you. That way, you won't give up and fall back into an inactive lifestyle. It's also important to understand that several elements of everyday life can help or hinder you in achieving your goals. What you eat has a strong bearing on your well-being, and so it's important to eat right. On top of that, there are lots of little things in everyday life that can bring about a positive result: like using the stairs instead of the lift. And remember, even if you don't do these things every day, every little bit helps.

# INSTRUCTIONS

Maximum user weight: 120kg

## Before You Start

Thank you for purchasing this Upright Bike! For your safety and benefit, read this manual carefully before using the machine.

Prior to assembly, remove components from the box and verify that all the listed parts were supplied. Assembly instructions are described in the following steps and illustrations.

## IMPORTANT SAFETY NOTICE

### PRECAUTIONS

BE SURE TO READ THE ENTIRE MANUAL BEFORE YOU ASSEMBLE OR OPERATE YOUR MACHINE. IN PARTICULAR, NOTE THE FOLLOWING SAFETY PRECAUTIONS:

- 01- Check all the screws, nuts and other connections before using the machine for the first time and ensure that the trainer is in the safe condition.
- 02- Set up the machine in a dry level place and leave it away from moisture and water.
- 03- Place a suitable base (e.g. rubber mat, wooden board etc.) beneath the machine in the area of assembly to avoid dirt and etc..
- 04- Before beginning training, remove all objects within a radius of 2 meters from the machine.
- 05- DO NOT use aggressive cleaning articles to clean the machine, Only use the supplied tools or suitable tools of your own to assemble the machine or repair any parts of machine. Remove drops of sweat from the machine immediately after finishing training.
- 06- Your health can be affected by incorrect or excessive training. Consult a doctor before beginning a training program. He can

define the maximum setting (Pulse. Watts. Duration of training etc) to which you may train yourself and can get precise information during training. This machine is not suitable for therapeutic purpose.

- 07- Only do training on the machine when it is in correct working way. Use only original spare parts for any necessary repairs.
- 08- This machine can be used for only one person's training at a time.
- 09- Wear training clothes and shoes which are suitable for fitness training with the machine. Your training shoes should be appropriate for the trainer.
- 10- If you have a feeling of dizziness, sickness or other abnormal symptoms, please stop training and consult a doctor as soon as possible.
- 11- People such as children and handicapped persons should only use the machine in the presence of another person who can give aid and advice.
- 12- The power of the machine increases with increasing the speed, and the reverse. The machine is equipped with adjustable knob which can adjust the resistance. Reduce the resistance by turning the adjusting knob for the resistance setting towards Level 1. Increase the resistance by turning the adjusting knob for the resistance setting towards Level 15.

**WARNING: BEFORE BEGINNING ANY EXERCISE PROGRAM, CONSULT YOUR PHYSICIAN. THIS IS ESPECIALLY IMPORTANT FOR INDIVIDUALS OVER THE AGE OF 35 OR PERSONS WITH PRE-EXISTING HEALTH PROBLEMS. READ ALL INSTRUCTIONS BEFORE USING ANY FITNESS EQUIPMENT.**

**SAVE THESE INSTRUCTIONS / Maximum user's weight: 120KGS.**



# EXPLODED DIAGRAM

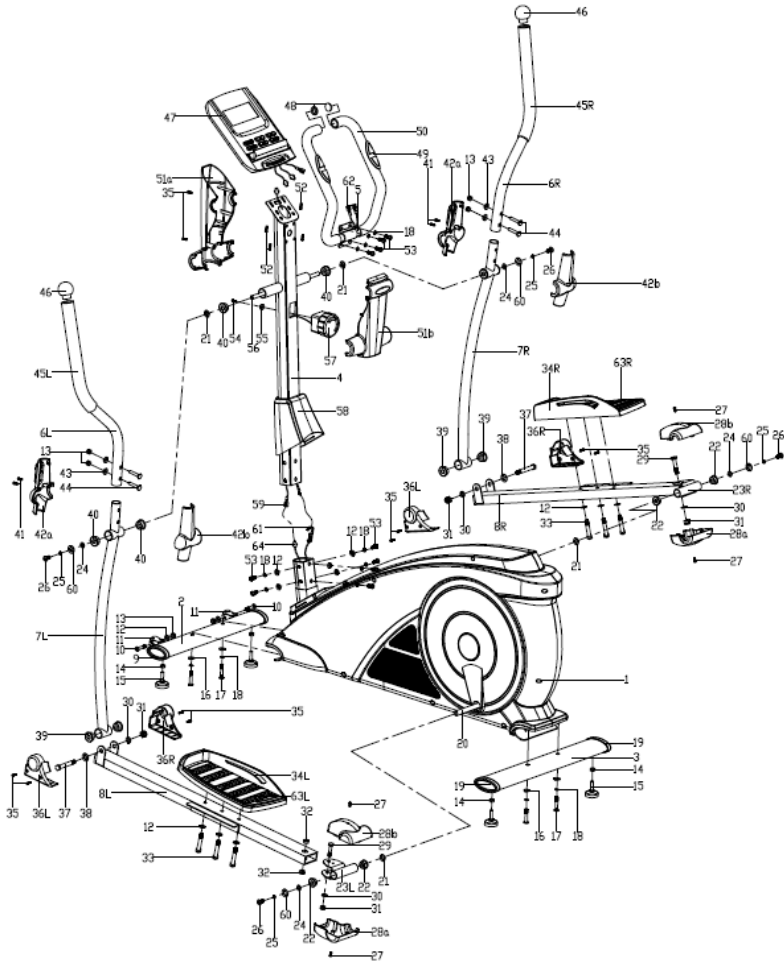

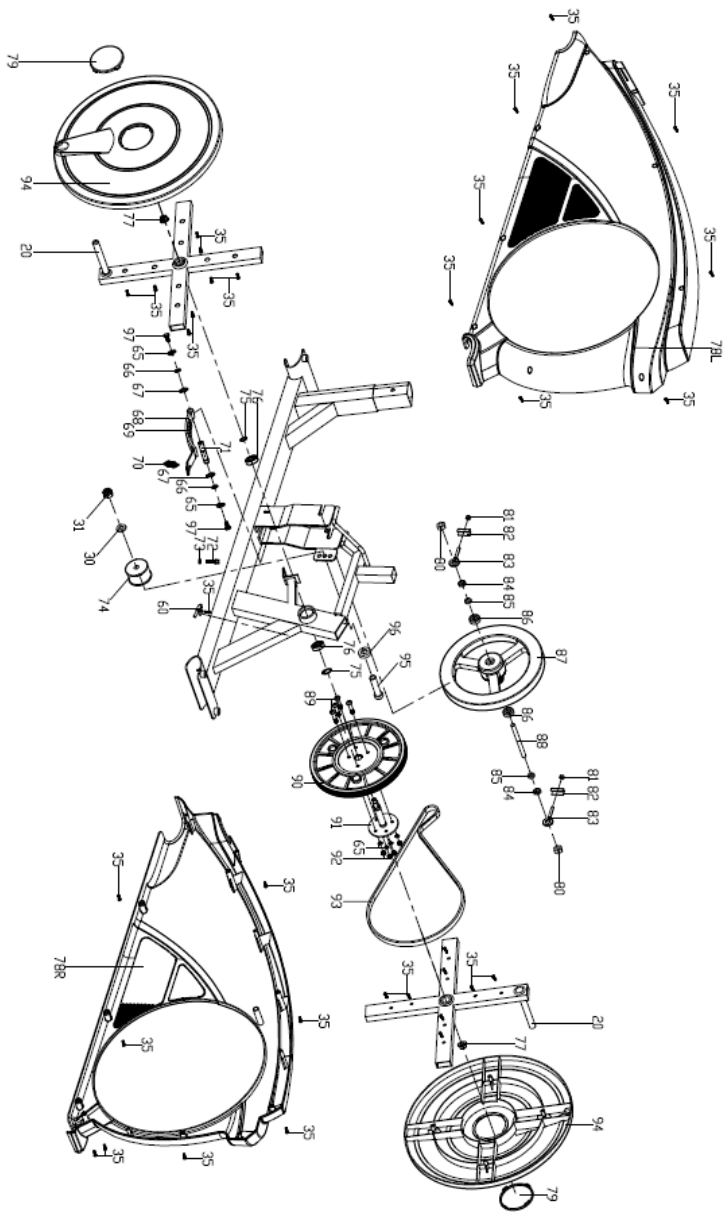

# PARTS LIST-A

Part No.	Description	Qty	Part No.	Description	Qty
1	Main frame	1	33	Hex bolt M8x45	6
2	Front bottom tube	1	34L/R	Pedal	1 Each
3	Rear bottom tube	1	35	Phillips tapping screw ST4.2x18	43
4	Handlebar post	1	36L/R	Protective cover	2 Each
5	Fixed handlebar	1	37	Hex Pivot bolt Φ12xM10x80	2
6L/R	Handlebar	1 Each	38	Flat washer D12xΦ24x1.5	2
7L/R	Swing arm	1 Each	39	Bushing Φ12xΦ32x15	4
8L/R	Pedal support	1 Each	40	Bushing Φ16xΦ31x23	6
9	Front Bottom Tube End cap	2	41	Phillips tapping screw ST3.5x10	4
10	Allen bolt M8x40xL12	2	42a/b	Swing arm cover	Each 2
11	Transport wheel	2	43	Arc washer D8xΦ19x1.5xR30	4
12	Flat washer D8xΦ16x1.5	14	44	Carriage bolt M8xL45	4
13	Nylon nut M8	6	45L/R	Foam grip	Each 1
14	Hex nut M10	4	46	Handlebar end cap	2
15	Leveler feet	4	47	Computer	1
16	Arc washer d8x2xΦ25xR39	4	48	Fixed handlebar end cap	2
17	Allen bolt M8xL58	4	49	Hand pulse sensor	2
18	Spring washer D8	14	50	Foam grip	2

19	Rear bottom tube End cap	2	51a/b	Computer cover	Each 1
20	Crank	2	52	Phillips Screw M4x10	4
21	Waved washer Φ17xΦ23x0.3	4	53	Allen bolts M8x16	10
22	Plastic bushing Φ24x16xΦ16.1	4	54	Phillips Screw M5x55	1
23L/R	Crank joint	1 Each	55	Arc washer D5	1
24	D-shaped washer Φ28xΦ16.2x14xB5	4	56	Long shaft	1
25	Spring washer D10	4	57	Tension knob	1
26	Allen bolt M10x20	4	58	Mast cover	1
27	Phillips Screw M5x10	4	59	Extension sensor wire	1
28a/b	Crank joint cover	2 Each	60	Flat washer D10*Φ20x2	4
29	Hex bolt M10x55	2	61	Tension cable	1
30	Flat washer D10xΦ20x2	4	62	Hand pulse wire	2
31	Nylon nut M10	4	63L/R	Pedal cushion	1pr.
32	Alloy Bushing Φ18xΦ10x11	4	64	Sensor wire with Sensor	1

## PARTS LIST-B

65	Spring washer D6	6	82	U-washer	2
66	Flat washer D6xΦ12x1.5	2	83	Adjusting Bolt	2
67	C-Clip washer D12	2	84	Thin nut M10x1	2
68	Magnetic board	1	85	Spacer D10x3	2
69	Square magnet	14	86	Flywheel Bearing 6000z	2
70	Tension control Spring	1	87	Flywheel	1

71	Magnet board axle	1	88	Flywheel axle	1
72	Hex bolt M5x60	1	89	Bolt M6x15	4
73	Hex nut M5	2	90	Belt pulley	1
74	Idler wheel	1	91	Middle axle	1
75	C-Clip washer D20	2	92	Nylon nut M6	4
76	Bearing 6904Z	2	93	Belt	1
77	Flange nut M10x1.25	2	94	Disk Cover	2
78L/R	Chain cover	1pr.	95	Bolt M10x40	1
79	Decorate Disk Cap	2	96	Spacer D10×Φ18×6	1
80	Hex nut M10x1	2	97	Hex bolt M6*15	2
81	Hex nut M6	2			

**NOTE:**

Most of the listed assembly hardware has been packaged separately, but some hardware items have been preinstalled in the identified assembly parts. In these instances, simply remove and reinstall the hardware as assembly is required.

Please reference the individual assembly steps and make note of all preinstalled hardware.

- ◆ Take time to review the manual and familiarize yourself with the entire assembly process before proceeding.
- ◆ Although this product can be assembled by one person, we recommend having the assistance of another individual. This is especially convenient when assembling multiple parts or moving the equipment.

**Assembly Tip:** It is always helpful to pre-stage the items needed for each assembly step.

# ASSEMBLY INSTRUCTIONS

## Step 01:

Install the Front bottom tube (2) and Rear bottom tube (3) to the Main frame (1) with the Allen bolts (17), Spring washers (18) and Arc washers (16) as shown.

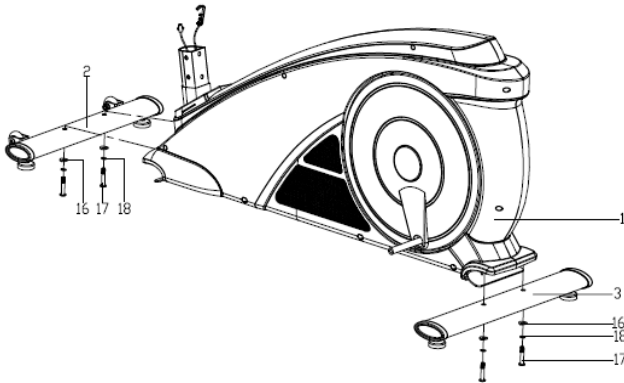

## Step 02:

A: Slide the Mast cover (58) onto the Handlebar post (4).

B: Connect the Extension sensor wire (59) with the Sensor wire (64) first, and then connect the Tension cable (61) with the Cable from the Tension controller (57) properly as shown.

C: Lock the Handlebar post (4) onto the Main frame (1) with the Allen bolts (53), Spring washers (18) and Flat washers (12), then slide down the Mast cover (58) and fit in place.

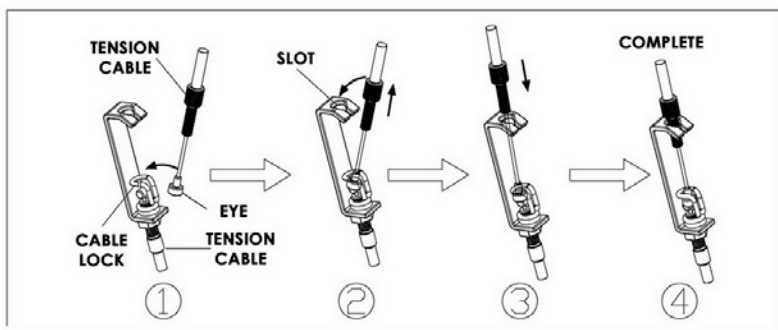
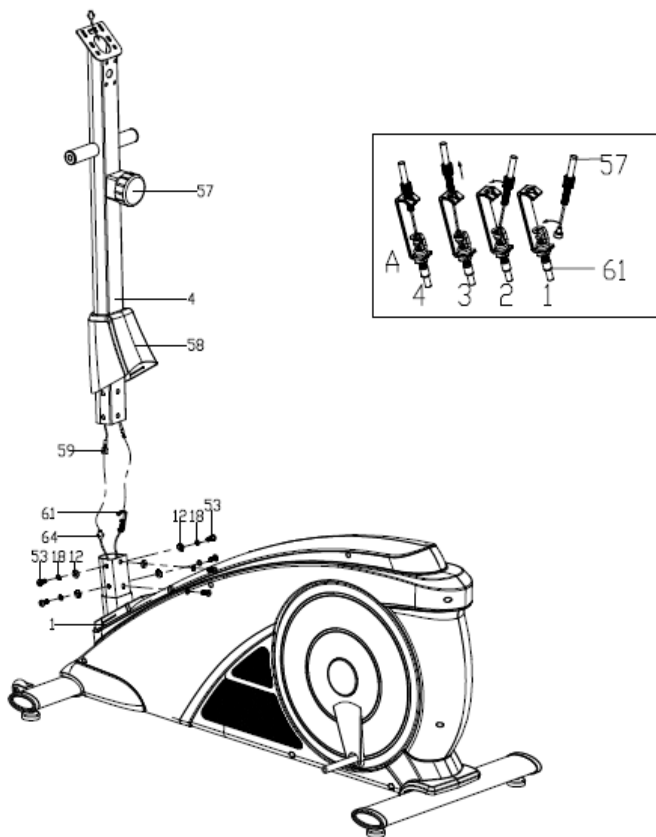

### Step 03:

A: Insert the Long shaft (56) to the Handlebar post (4), then attach the Swing tube (7L/R) on the Long shaft (56) with the Allen bolts (26), Spring washers (25), Flat washer(60), D-shaped washers (24) and Wave washers (21). Attention: Don't lock them tightly now.

B: Fix the Pedal support (8L/R) on the Crank (20) with the Allen bolt (26), Spring washer (25), Flat washer(60),D-shaped washer (24) and Wave washer (21). Attention: Don't lock them tightly now.

C: Connect the Swing arm (7L/R) and Pedal support (8L/R) together with the Hex Pivot bolts (37), Flat washers (38), Flat washers (30) and Nylon nuts (31). Then recheck and lock the above mentioned Allen bolts (26), Hex Pivot bolts (37) and Nylon nuts (31) tightly.

D: Lock the Pedal (34L/R) on the Pedal support (8L/R) tightly with the Hex bolts (33) and Flat washers (12) as shown.

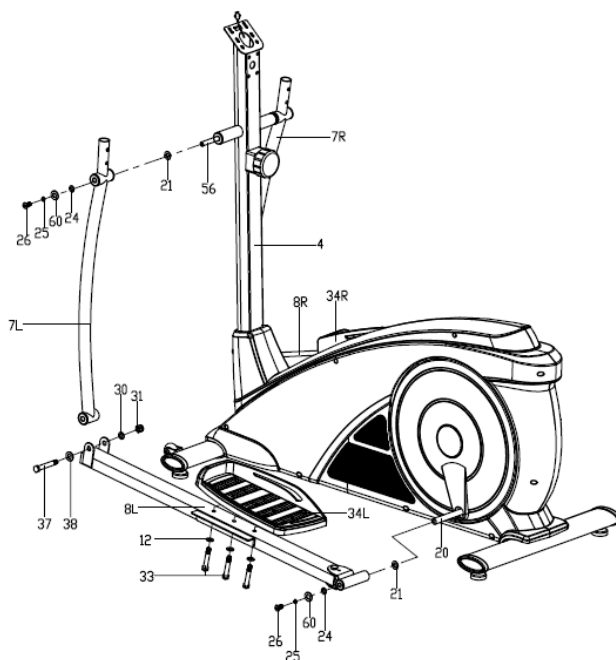



## Step 04:

A: Lock the Handlebar (6L/R) on the Swing arm (7L/R) tightly with the Carriage bolts (44), Arc washers (43) and Nylon nuts (13);

B: Through the Hand pulse wires (62) into the hole of Handlebar post (4) and then take it out from the computer bracket. Lock the Fixed handlebar (5) to the Handlebar post (4) tightly with the Allen bolts (53) and Spring washers (18) as shown.

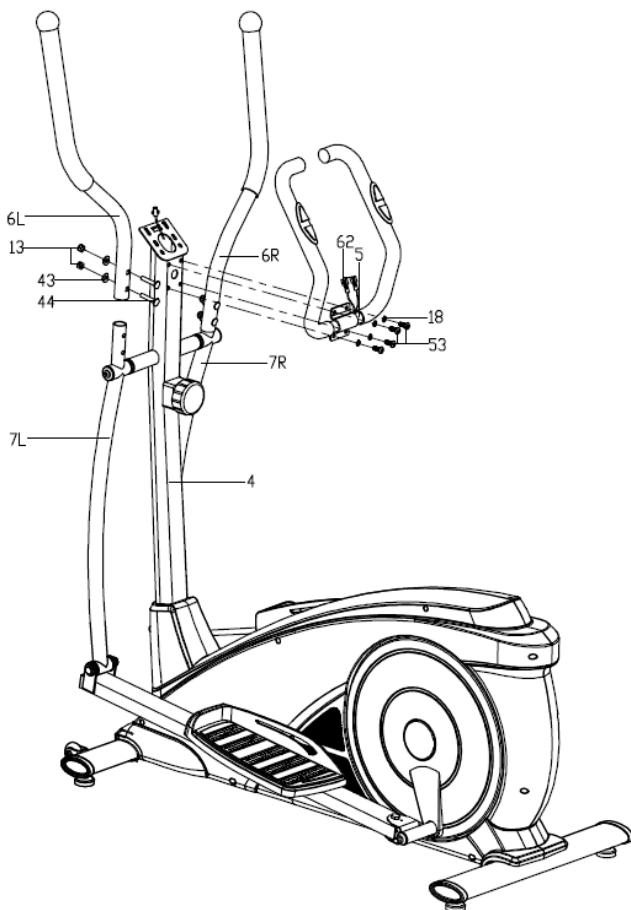

## Step 05:

A: Fix the Swing arm cover (42a/b) on the Swing arm (7L/R) with the Phillips tapping screws (41);

B: Fix the Protective cover (36L/R) on the connecting joint of Swing arm (7L/R) and Pedal support (8L/R) with the Phillips tapping Screws (35);

C: Fix the Crank joint cover (28a/b) on the Crank joint (23L/R) with the Phillips Screws (27) as shown.

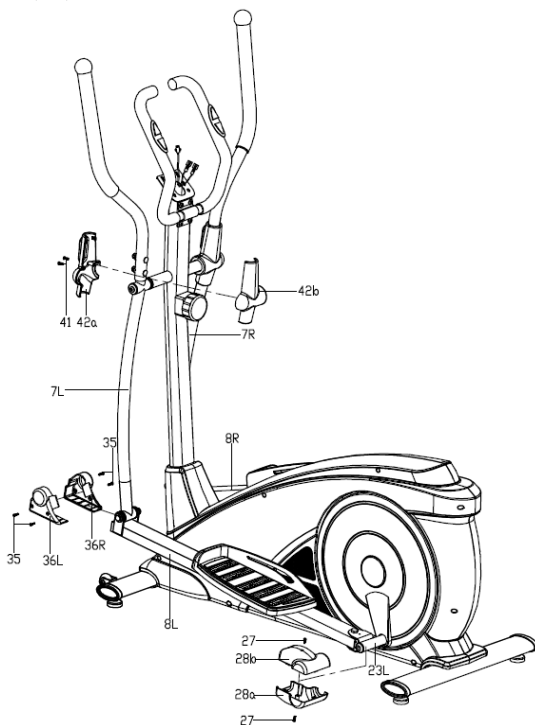

## Step 06:

A: First, connect the Extension sensor wire (59) and Hand pulse wires (62) with the connecting wires coming out from the Computer (47) respectively, then fix the Computer (47) on the bracket of the Handlebar post (4) with the Phillips Screws (52);

B: Lock the Computer cover (51a/b) on the Handlebar post (4) tightly with the Phillips tapping Screws (35) as shown.

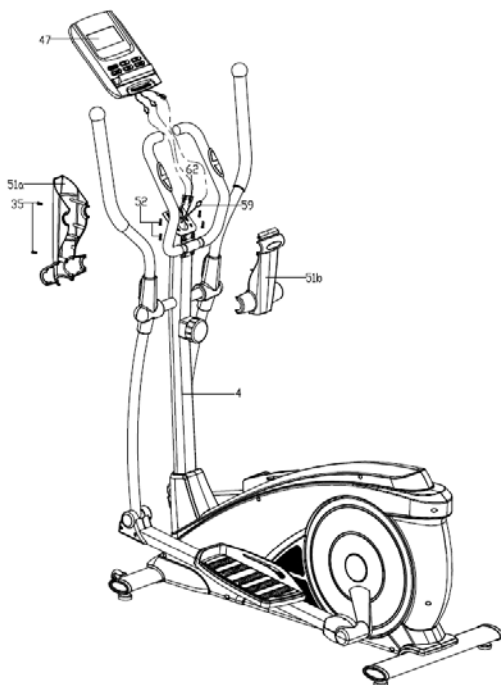

**Note:**

Before use this Machine, please check the Stability;  
You can adjust the Stability by screwing the Adjustable Pad (15) under the Stabilizers to fit the Ground.

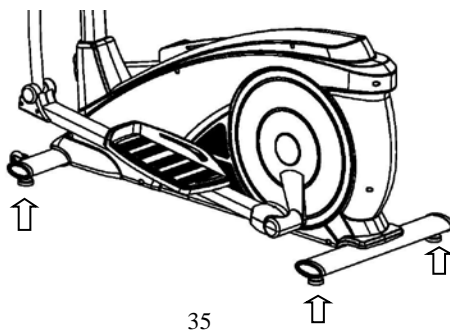

# COMPUTER MANUAL

The things you should know before exercise

## A. User Data:

You should input your personal data before workout. Press BODY FAT key to enter your personal data of sex, age, height and weight then the computer can save the data unless take out the batteries.

## B. Clock Mode:

- a. The computer will enter the clock mode when there is no signal input or no keys be pressed after 4 minutes. You can press ENTER key to switch the clock and temperature at the clock mode or press other keys to quit the clock mode.
- b. You can setup the CLOCK by holding UP+ENTER keys; and ALARM by holding DOWN+ENTER keys for over 2 seconds, then you can quit by ENTER key.
- c. By holding the ENTER and UP keys together for over two seconds, you can check the current clock at "NO SPEED" mode.

Functions and Features:

1. CLOCK: Display the current clock in hour and minute and second.
2. ALARM: You can set up your morning call or setting time by this computer and it will beep alarm 1 minute when your setting time is reached.
3. TEMPERATURE: Display the current temperature.
4. SCAN: During the exercise stage, the computer will automatically scan the function of TIME, SPEED, DISTANCE, CALORIES, PULSE and RPM per each for 6 seconds unless press the ENTER key to exit the auto-scan function. When the computer exits the manual-scan then the message window will show "SCAN" for 2 seconds then switch to auto-scan function.
5. TIME: Shows your elapsed workout time in minutes and seconds. Your computer will automatically count up from 0:00 to 99:59 in one second intervals. You many also program your computer to count down from a set value by using the UP and DOWN keys. If you continue exercising once the time has reached 0:00, the computer will begin beeping, and reset itself to the original time set, letting you know your workout is done.
6. SPEED: Displays your workout speed value in KM/MILE per hour. If no speed signal input then the computer will display "NO SPEED" on the window.

7. DISTANCE: Displays the accumulative distance traveled during each workout up to a maximum of 99.9KM/MILE.
8. CALORIES: Your computer will estimate the cumulative calories burned at any given time during your workout.
9. PULSE: Your computer displays your pulse rate in beats per minute during your workout. If no pulse signal input then the computer will display "NO pulse" on the window.
10. RPM: Your pedal cadence.
11. AGE: Your computer is age-programmable from 10 to 99 years. If you do not set an age, this function will always default to age 35.
12. PULSE RECOVERY: During the START stage, leave your hands holding on grips or leave the chest transmitter attached and then press "PULSE RECOVERY" key,time starts counting from 01:00 - 00:59 - - to 00:00. As soon as 00:00 is reached, the computer will show your heart rate recovery status with the grade F1.0 to F6.0 and message window will show your workout situation. The details as follows,

- 1.0 means OUSTANDING**
- 1.0 < F < 2.0 means EXCELLENT**
- 2.0 ≤ F ≤ 2.9 means GOOD**
- 3.0 ≤ F ≤ 3.9 means FAIR**
- 4.0 ≤ F ≤ 5.9 means BELOW AVERAGE**
- 6.0 means POOR**

13. Voice Functions:

a. On pressing UP and DOWN keys both for 2 seconds, the monitor can automatically speak "WELCOME" in 30-second interval. Meanwhile, LCD will show 8888 for 3 seconds and then shows the clock mode.

b. You can start or stop the voice function by pressing UP + DOWN+ENTER keys both for 2 seconds. The voice instruction "ON" means " welcome to use"; "OFF" means "DONE".

Key function:

There are 6 button keys and the function description as follows:

1. UP key: During the setting mode, press the key to increase the value of Time, Distance, Calories, Age, Weight, Height etc. and to select sex. During the CLOCK mode, you can set up clock and alarm by this key.
2. DOWN key: During the setting mode, press the key to decrease the value of Time, Distance, Calories, Age, Weight, Height

etc. and to select sex. During the CLOCK mode, you can set up clock and alarm by this key.

**Note:** During the setting mode, you can hold UP and DOWN keys together for over two seconds then the setting value will reset to Zero or default value.

3. ENTER/RESET key: a. Press the key to accept the current data entry.  
b. During the "NO SPEED" mode, by holding this key for over two seconds then the computer will re-power-on.
4. BODY FAT key: Press the key to enter your personal data before measure your body fat ratio.
5. MEASURE key: Press the key to get your body fat ratio and BMI and BMR.
  - a. **FAT %:** Indicate your body fat percentage after measurement.
  - b. **BMI (Body Mass Index):** BMI is a measure of body fat based on height and weight that applies to both adult men and women.
  - c. **BMR (Basal Metabolic Rate):** Your Basal Metabolic Rate (BMR) shows the number of calories your body needs to operate. This doesn't account for any activity, it's simply the energy needed to sustain a heartbeat, breathing and normal body temperature. It measures the body at rest, not sleep, at room temperature.
6. PULSE RECOVERY key: Press the key to activate heart rate recovery function.

Error Message:

E: The speed over than 99.9 MPH/KPH then the computer will display "E".

Err: When measure the body fat function or pulse recovery function, if there is no pulse signal input within 20 seconds then the computer will display "Err". You can repress any keys to quit the Err message.



Directive	Standard
ROHSDirective 2011/65/EU	
The General Product Safety Directive (GPSD) (2001/95/EC)	EN ISO 20957-1:2013 EN957-9:2003
Electromagnetic Compability (EMC) Directive 2014/30/EU	EN61000-6-1:2007

Signed for and on behalf of :

Place of issue: Taiyuan, Shanxi ,China  
 Date of issue: Oct 10,2017  
 Name : Ms.Lucy Kong  
 Position: Sales manager  
 Signature



The technical documentation for equipment is available from the above address.



\_\_\_\_\_

\_\_\_\_\_

\_\_\_\_\_

\_\_\_\_\_

\_\_\_\_\_

\_\_\_\_\_

\_\_\_\_\_

\_\_\_\_\_